

Model Number	2LE022	2LE023	2LE024	2LE025
HP	2	2	2	2
Volts	200/230*	200/230*	460	575
Phase	1	3	3	3
Hz	60	60	60	60
RPM	1725	1725	1725	1725
FLA	13.7	9	4.3	3.4
LRA	36.7	38.6	19.3	15.4
Max kW Input	3	3	3	2.9
Service Factor	1	1	1	1
Power Factor (%)	0.91	0.83	0.82	0.81
KVA Code	C	J	J	H
Std Impeller Diameter (in)	6.4	6.4	6.4	6.4
Shut-Off Head (ft)	37	37	37	37
Min Head (ft)	5	5	5	5
Max Flow @ Min Head (GPM)	400	400	400	400
Power Cord Type & Diameter	14/3, SOOW, 0.526 in	14/4, SOOW, 0.526 in	14/4, SOOW, 0.526 in	14/4, SOOW, 0.526 in

\*System voltages: 208 and 240 volts with utilization voltages: 200 and 230 volts

Motor Insulation Class	F
Max Stator Temp	135°C (1-phase thermal protector)
Impeller Type	Open 2 Vane
Impeller Material (Std)	Class 30 Cast Iron
Impeller Material (Optional)	Bronze
Power Cord Length (Options)	35, 50, 100 ft
Quick-connect Cord	Standard
Seal Material	Silicon Carbide/Silicon Carbide Buna Elastomers
Max Water Temp for Continuous Duty	40°C
Min Fluid Level for Continuous Operation	Motor Housing Fully Submerged
Fluid pH Range	4–10
Shaft Material	303 Stainless Extension
Fastener Material	316 Stainless Steel
O-Ring Elastomers	Buna-N

Upper Bearing	Single Row Deep Groove Radial Contact
Lower Bearing	Single Row Deep Groove Radial Contact
Oil Type	ISO VG 10 Turbine Oil
Max Submersion Depth	75 ft
Solids Handling	2.5 in
Discharge (Std)	Horizontal, 3 in 150# ANSI
Discharge (Optional)	Vertical 3 in NPT
Protective External Finish	Epoxy Powder Coat
Thermal Protection	1-phase - Hermetically Sealed Thermal Protector 3-phase - Overloads Required in Panel
Volute Material	Class 30 Cast Iron
Pump Weight	300 lbs
Certifications	CSA Certified to CSA and UL® Standards CAN/CSA C22.2 No. 108 ANSI/UL 778

Specifications are subject to change without notice.

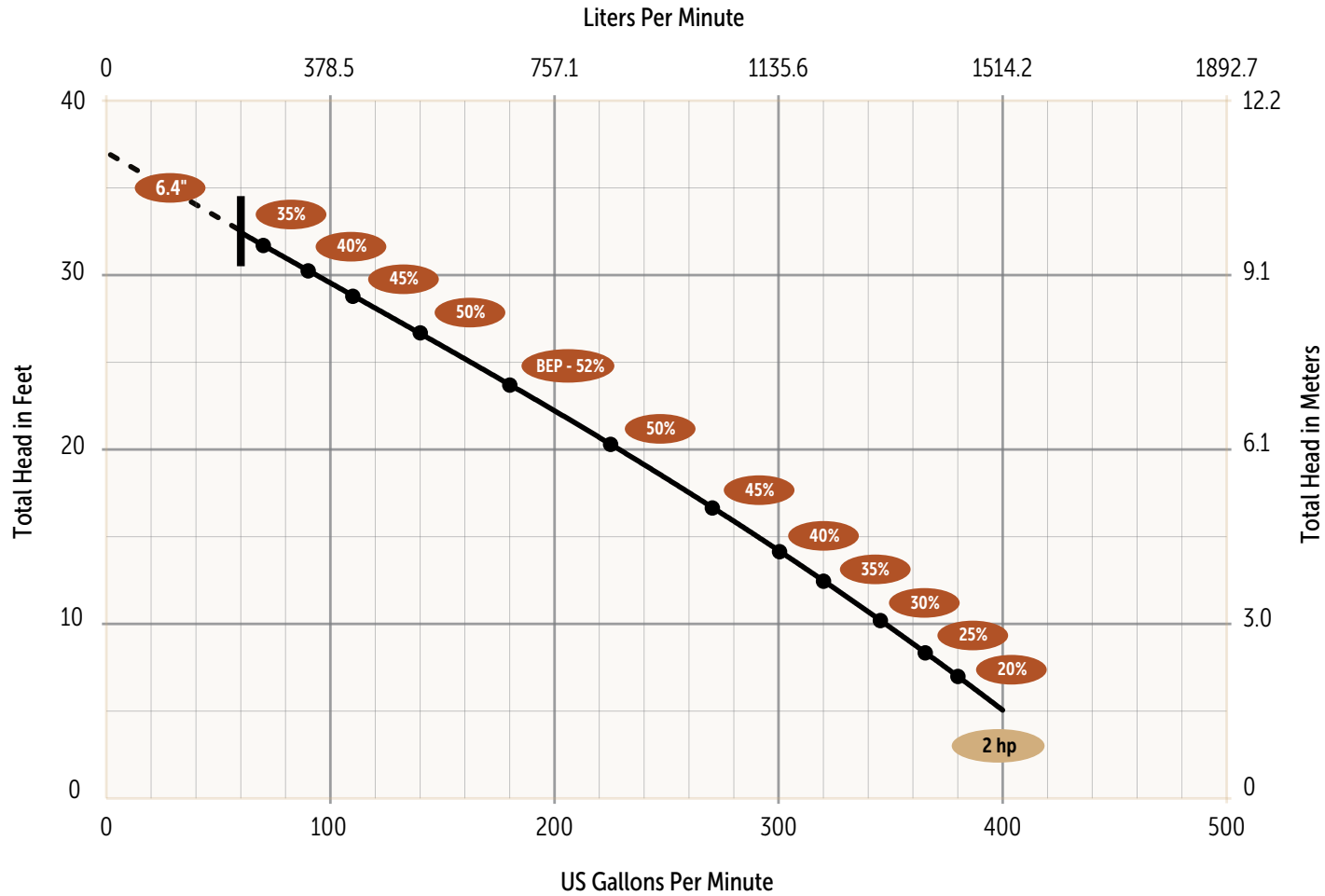

\*Stated efficiency values are Hydraulic Efficiency. Wire-to-Water efficiency information is available upon request.

\*Pumps must operate within the proper range shown on the performance chart. It is the responsibility of the end user to ensure this requirement is met. Pumps operating outside the recommended range are prone to damage, excessive vibration, cavitation, poor efficiency, and will exceed nameplate amperage.

Specifications are subject to change without notice.

## Horizontal Discharge

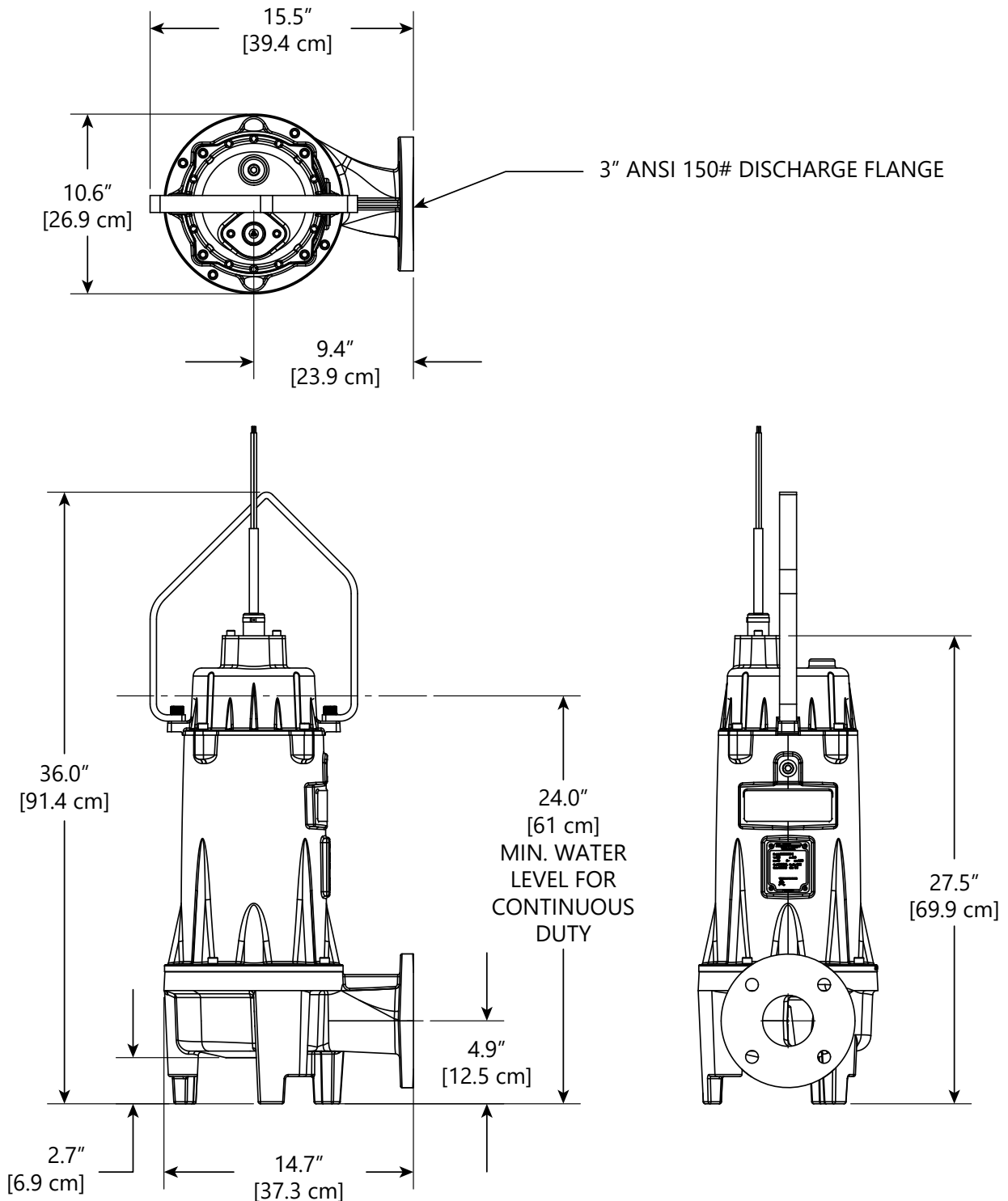

## Vertical Discharge

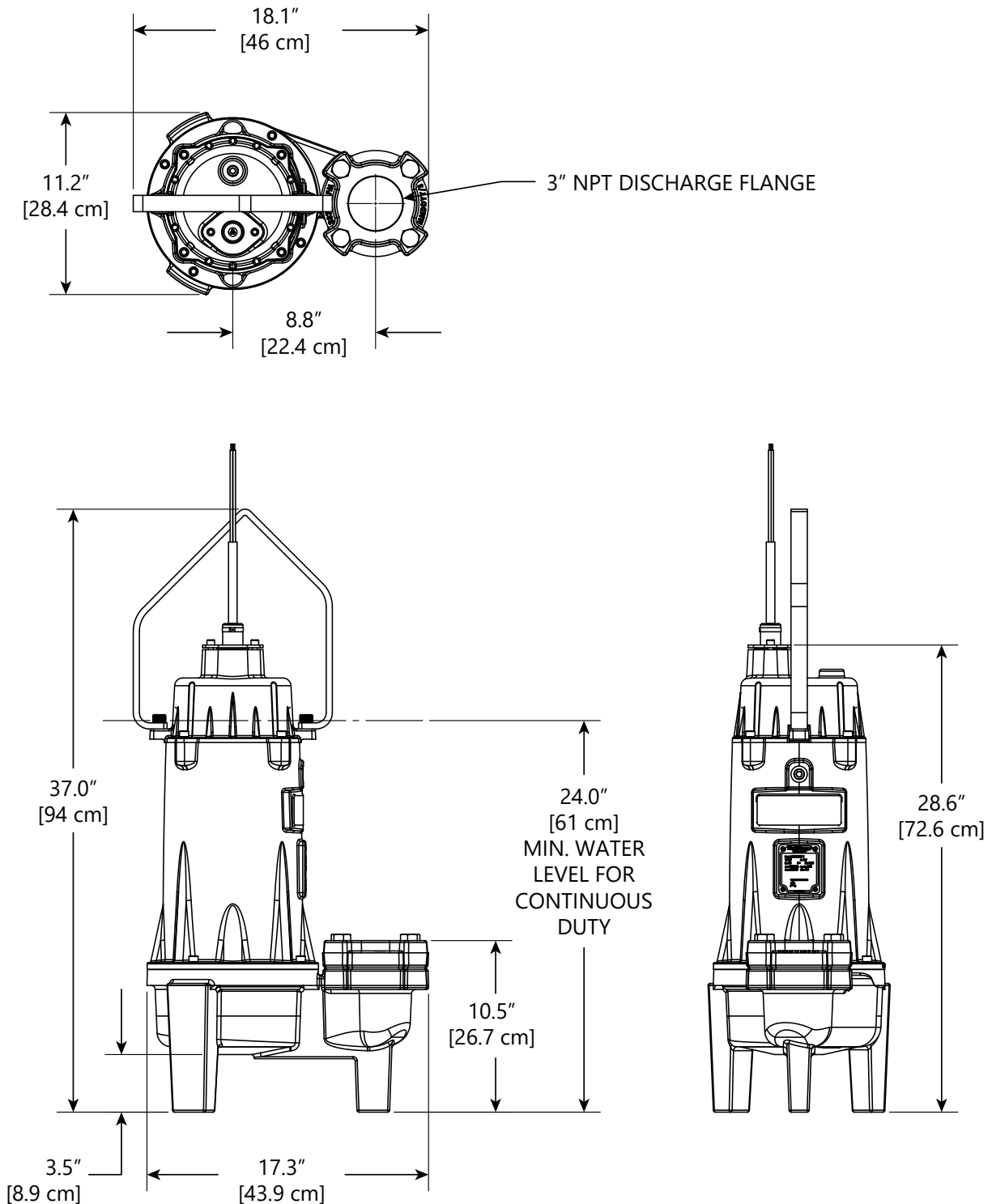

Specifications are subject to change without notice.

## GENERAL

The contractor shall provide labor, material, equipment, and incidentals required to provide \_\_\_\_\_ (QTY) sewage pumps as specified herein. The pump models covered in this specification are 1-phase model 2LE022, and 3-phase models 2LE023, 2LE024, and 2LE025 open 2 vane pumps. The pump furnished for this application shall be model \_\_\_\_\_ as manufactured by Liberty Pumps.

## OPERATING CONDITIONS

Each submersible pump shall be rated at 2 hp, \_\_\_\_\_ Volts, \_\_\_\_\_ phase, 60 Hz, 1725 RPM. The unit shall produce \_\_\_\_\_ GPM at \_\_\_\_\_ feet of total dynamic head.

The submersible pump shall be capable of handling residential and commercial sewage with 2.5" solids handling capability. The 2LE02-Series submersible pump shall have a shut-off head of 37 feet and a max flow of 400 GPM @ 5 feet of total dynamic head.

## CONSTRUCTION

Each centrifugal sewage pump shall be equal to the Certified 2LE02-Series pumps as manufactured by Liberty Pumps, Bergen NY. The casting enclosing the motor shall be constructed of class 25 cast iron. The motor housing shall be oil-filled to dissipate heat. Air-filled motors shall not be considered equal since they do not properly dissipate heat from the motor. Mating parts shall be machined and sealed with a Buna-N O-ring. All fasteners exposed to the process fluid shall be stainless steel. The motor shall be protected on the top side with a sealed cast iron cord entry plate. The motor shall be protected on the lower side with a single mechanical seal. The seal shall be a two-piece mechanical seal with silicon carbide faces. The upper and lower bearings shall be sized to properly withstand radial and thrust loads produced throughout the full operating range of the pump.

## POWER CORD

The submersible pump shall be supplied with 35, 50, or 100 feet of a multi-conductor cord of type SOOW. These type SOOW power cords carry a voltage rating of 600 V, a temperature rating of 90°C, have oil-resistant insulation, are water- and weather-resistant, UL listed, and CSA approved. The power cord shall be sized for the rated full load amps of the pump for continuous duty in accordance with the NEC®.

Standard Quick-connect cord shall offer quick cord replacement without the need to send the entire pump to an authorized repair facility. This shall also allow for pump maintenance without disturbing electrical boxes or control panels.

## MOTOR

The motor shall be oil-filled, Class F insulated, and rated for continuous duty. Since air-filled motors are not capable of dissipating heat efficiently, they shall not be considered equal. This motor design shall provide significantly reduced operating temperatures. Pumps requiring an auxiliary cooling means shall not be considered equal.

The copper stator windings shall be insulated with moisture-resistant Class F insulation materials, rated for 155°C. The maximum continuous temperature of pumped liquids shall be 40°C. The winding operating temperature at rated horsepower and service factor shall be a maximum of 140°C @ 40°C ambient.

Motor shall have thermal protector on 1-phase model 2LE022 to cut power to motor in thermal overheat conditions.

## CONTROL PANEL

All 2LE02-Series pumps require a control panel. The control panel shall be equipped with circuit breakers and adjustable overload devices to protect against excess current or electrical problems. 1-phase model 2LE022 shall additionally require run capacitors. External capacitor models (ending in -C) require capacitors in the control panel. The control panel shall be sized appropriately for the pump model(s) being controlled.

Pump Model (Horizontal & Vertical models)	Voltage	Control Panel Model		
		3 Float Simplex	3 Float Duplex	4 Float Duplex
2LE022	200/230	SXL24=3	AE24L=3	AE24L=4
2LE022-C*	200/230	SX24LC1=3	AE24LC2=3	AE24LC2=4
2LE023	200/230	SX34=3-511	AE34=3-511	AE34=4-511
2LE024	460	SX34=3-171	AE34=3-171	AE34=4-171
2LE025	575	SX54=3-151	AE54=3-151	AE54=4-151

\* 1-Phase Cap Kit K001745 required

## BEARINGS AND SHAFT

The shaft shall be supported by two radial ball bearings. Both bearings shall be permanently lubricated by the oil that fills the motor housing. Pump designs requiring scheduled bearing maintenance shall not be considered equal.

The motor shaft extension shall be made of 303 stainless steel. The shaft shall be designed to withstand the maximum torque and radial loads present during start-up and normal operation.

## SEAL

---

The pump shall have one shaft seal. The mechanical seal shall be a two-piece design that is easily serviceable. Shaft seal shall not require scheduled maintenance. Seal shall be silicon carbide on silicon carbide. Seal shall include stainless steel housings and Buna elastomers.

## IMPELLER

---

The impeller shall be ASTM class 30 cast iron, with optional silicon bronze material available. The open 2 vane impeller design provides an efficient path through the impeller for solids to pass without getting caught or snagged. The impeller shall be keyed and bolted onto the motor shaft.

## QUALITY CONTROL

---

The pump shall be manufactured in an ISO® 9001 certified facility. Manufactured in the USA with US and global components.

## SUPPORT

---

The pump shall have cast iron support legs, enabling it to be a freestanding unit. The legs shall be high enough to allow solids and long, stringy debris to enter the pump inlet.

## PROTECTIVE FINISH

---

The exterior of the casting shall be protected with corrosion-resistant baked-on epoxy powder coat.

## TESTING

---

The pump shall have a ground continuity check and undergo a hi-pot test for electrical integrity, moisture content, and insulation defects. The motor housing shall be pressurized, and an air leak decay test performed to ensure integrity of the assembled unit. The pump shall be run, voltage and current monitored, and checked for noise or other malfunction. Certified performance testing is available upon request.

## APPLICATIONS

---

- Municipal Engineered Lift Stations
- Storm Water Removal
- Wastewater Transfer
- Industrial Wastewater
- Treatment Plants

## MATERIAL FEATURES: PUMP

---

- Solids - 2.5" Spherical Capability
- Discharge - Horizontal 3" 150# ANSI
- Seal - Silicon Carbon/Silicon Carbide
- Construction - Cast Iron ASTM A48, Class 25, 25,000# Tensile Strength, Protected with a Corrosion-Resistant Baked-on Epoxy Powder Coating
- Hardware - Stainless Steel
- O-ring Seals - Buna-N
- Cast Iron Impeller - Open 2 Vane
- Standard Quick-connect Power Cord
- Thermal Protector on 1-phase Models
- Optional:
  - Vertical Discharge
  - Cord Length Options (feet) - 35, 50, 100
  - Silicon Bronze Impeller
  - Internal or External Capacitors on 1-phase Models

## MATERIAL FEATURES: MOTOR

---

- 1-Phase - 200/230 Volt, 1725 RPM
- 3-Phase - 200/230, 460, 575 Volt, 1725 RPM
- Class F Insulation
- Oil-filled Motor Housing
- Cast Iron Housing
- Continuous Duty Operation
- Bearings
  - Upper - Single Row Deep Groove Radial Contact
  - Lower - Single Row Deep Groove Radial Contact



Engineered**Products**

## LIMITED WARRANTY

---

Liberty Pumps, Inc. warrants that pumps of its Engineered Product line are free from all factory defects in material and workmanship for a period of 18 months from the date of installation or 24 months from the date of manufacture, whichever occurs first, and provided that such products are used in compliance with their intended applications as set forth in the Liberty Engineered Products specifications and technical manuals. The date of installation shall be determined by a completed pump start-up report and warranty registration form.

A pump startup report, filled out by a qualified installer, is required for warranty to take effect. The report must be submitted within 30 days from the installation date and submitted through the Liberty Pumps website. During the warranty period, the manufacturer's obligation, and at its discretion, shall be limited to the repair or replacement of any parts found by the manufacturer to be defective, provided the product is returned freight prepaid to the manufacturer or its authorized service center, and provided that none of the following warranty-voiding characteristics are evident:

The manufacturer shall not be liable under this Warranty if the product has not been properly installed or maintained in accordance with the printed instructions provided; if it has been disassembled, modified, abused or tampered with; if the pump discharge has been reduced in size; if the pump has been used in water temperatures above those shown in the specifications; if the thermal overload(s) and seal moisture probe(s) have not been properly connected (where equipped); if the pump has been used in water containing sand, lime, cement, gravel or other abrasives; if the product has been used to pump chemicals or hydrocarbons; if the product has been moved from its original installation location, or if the label bearing the serial and code number has been removed.

Liberty Pumps, Inc. shall not be liable for any loss, damage or expenses resulting from installation or use of its products, or for consequential damages, including field labor costs, travel expenses, rental equipment, costs of removal, reinstallation or transportation to and from the factory or an authorized Liberty Pumps repair facility.

There is no other express warranty. All implied warranties, including those of merchantability and fitness for a particular purpose, are limited to 18 months from the date of installation or 24 months from the manufacturing date. This Warranty contains the exclusive remedy of the purchaser, and, where permitted, liability for consequential or incidental damages under any and all warranties are excluded.

Specifications are subject to change without notice.